



2.2.3

V40G SERIES

Swash-plate Type Axial Piston Variable Displacement Pump

V40G series axial piston pump is a ultrahigh pressure closed circuit pump, which can meet the application requirements of customers for harsh working conditions such as high pressure, high rotational speed and frequent impact.

Suitable for a ultrahigh-pressure closed circuit

Size :	145	175	215	280
Rated pressure (bar):	450	450	450	450
Max. pressure (bar):	500	500	500	500

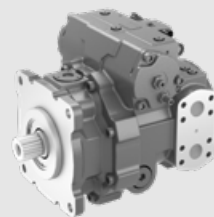

Contents

Technical Data	02-03
Type introduction	04-06
Hydraulic fluid	07
Shaft seal	08
E - Electrical displacement control	09
Proportional control, H2 - hydr., pilot-pressure related	10
Control principle & Installation size	
·V40G 145 type	11-15
·V40G 175 type	16-20
·V40G 215type	21-25
·V40G 280 type	26-30

Features

- Variable axial piston pump of swashplate design for hydrostatic drives in closed circuit.
- Flow direction changes smoothly when the swashplate is moved through the neutral position.
- Two pressure relief valves are installed on the high-pressure side to prevent overload.
- The built-in charge pump acts as charge pump and control pump.
- The maximum charge pressure is limited by the built-in low pressure relief valve.
- New rotary components and bearings, make the transmission efficiency improved, and the input speed increased.
- The V40G pump adopts an integrated design at the rear of the housing to reduce leaking points.
- Optimized shell design to reduce vibration and noise.
- Electric proportional displacement control meets the application requirements of multiple industries.
- Various oil outlet connection methods help to optimize pipeline connection.
- V40G pump can be optionally equipped with a flush valve, which can be directly installed on the pump body.

Technical data

Size		145	175	215	280
Displacement (cc/rev)		145.3	175.4	215.7	280
Speed	Rated (rpm)	2850	2650	2500	2400
	Max. (rpm)	3000	2800	2650	2550
	Min. (rpm)	500	500	500	500
Pressure	Rated (bar)	450	450	450	450
	Max. (bar)	500	500	500	500
	Minimum low loop pressure (bar) (Above charge pump)	10	10	10	10
Charge pump displacement (cc/rev)		32	39	47	60
Charge pressure (relative to Charge pump)	Max. (bar)	40	40	40	40
Casting pressure	Rated (bar)	2	2	2	2
	Max. (bar)(Short-time peak pressure)	5.0	5.0	5.0	5.0
Suction pressure (Absolute pressure)	Rated (bar) Oil viscosity $\leq 30\text{mm}^2/\text{s}$	0.8	0.8	0.5	0.8
	Max. (bar)	6	6	5	5
Oil viscosity (mm ² /s)		10~1000, Best range: 16~36			
Oil temperature (°C)		-20~95			
Oil cleanliness		ISO 4406 Class 20/18/15 or higher			
Weight (w/o auxiliary flange) (Kg)		110	115	146	179.4

Technical data

Permissible input and through-drive torques						
Size			145	175	215	280
Torque at $V_{g\max}$ and $\Delta p = 430$ bar Nm		T	992	1197	1471	1916
Maximum input torque at drive shaft (Nm)						
ANSI B92.1b	1 3/4 in 13T 8/16 DP	$T_{E\max}$	1640	1640		
	1 3/4 in 27T 16/32 DP	$T_{E\max}$	1830			
	2 in 15T 8/16DP	$T_{E\max}$	2670		2670	2670
	2 1/4 in 17T 8/16 DP	$T_{E\max}$	4070	4070	4070	4070
	W50×2×24×9g	$T_{E\max}$	3140	3140		
	W55×2×26×9gw	$T_{E\max}$			4350	4350
Maximum through-drive torque (Nm)		$T_{D\max}$	1760	1760	2641	2641

•Torque distribution

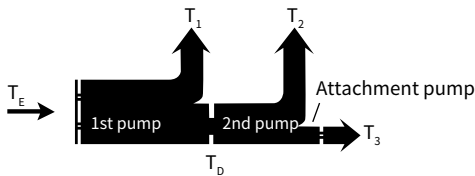

V40G	1st pump	T_1
	2nd pump	T_2
Attachment pump		T_3
Input torque		$T_E = T_1 + T_2 + T_3$
		$T_E < T_{E\max}$
Through-drive torque		$T_D = T_2 + T_3$
		$T_D < T_{D\max}$

Type introduction

V40	G	280	E1	A	D	/	R	N	E3	1	FD	D4	8	D	-	
①	②	③	④	⑤	⑥		⑦	⑧	⑨	⑩	⑪	⑫	⑬	⑭		⑮

Product series

①	Variable piston pump of swashplate in closed circuit	V40
---	--	-----

Nominal pressure

②	nominal pressure 450 bar	G
---	--------------------------	---

Size

③	Size	145	175	215	280
---	------	-----	-----	-----	-----

Control mode

		145	175	215	280	Code
④	Proportional control (electric U = 12 V DC)	●	●	●		E1
	Proportional control (electric U = 24 V DC)	●	●	●	●	E2
	Proportional control (electric U = 12 V DC), explosion proof electromagnetic coil	○	○	○	○	E5
	Proportional control (electric U = 24 V DC), explosion proof electromagnetic coil	●	●	○	●	E6
	Hydraulic pilot proportional control	●	●	●	●	H2

DA control

		145	175	215	280	Code
⑤	Without swivel DA control	●	●	●	●	Blank
	Swivel DA control				●	A

Pressure cut-off

⑥	Without pressure cut-off	Blank
	Pressure cut-off	D

Rotation

⑦	Right hand (clockwise)	R
	Left hand (counter-clockwise)	L

Type introduction

Oil port specifications and sealing

	Seals	A/B Port Specifications	S Port Specifications	Port Specifications (excluding A/B/S ports)	145	175	215	280	Code
⑧	Sealed at room temperature	ISO 6162&SAE J518	ISO 6162&SAE J518	ISO 6149			●	●	H
		ISO 6162&SAE J518	DIN 3852	DIN 3852	●	●			J
	Sealed at low temperature	ISO 6162&SAE J518	DIN 3852	DIN 3852		●			W

Mounting flangew and drive shaft

	Mounting flange	Drive shaft	145	175	215	280	Code
⑨	SAE D J744-152-2/4	ANSI B92.1b 1 3/4 in 13T 8/16 DP	●	●			D1
		ANSI B92.1b 1 3/4 in 27T 16/32 DP	●				D2
		ANSI B92.1b 2 in 15T 8/16 DP	●				D3
		ANSI B92.1b 2 1/4 in 17T 8/16 DP	●	●			D7
		DIN 5480 W50×2×24×9g	●	●			D6
	SAE E J744-165-4	ANSI B92.1b 1 3/4 in 13T 8/16 DP	●	●			E1
		ANSI B92.1b 1 3/4 in 27T 16/32 DP	●				E2
		ANSI B92.1b 2 in 15T 8/16DP	●		●	●	E3
		ANSI B92.1b 2 1/4 in 17T 8/16 DP	●	●	●	●	E4
		DIN 5480 W50×2×24×9g	●	●			E5
	DIN 5480 W55×2×26×9g			●	●	E6	

Working port

	A/B Port Configuration	S Port Location	145	175	215	280	Code
⑩	A and B ports on the same side face right	S port is located at the bottom	●	●	●	●	1

Note: The control valve seat faces upward when viewed from the input shaft end.

Boost pump and rotary group configuration

Standard rotary group, without boost pump							K
⑪	Standard rotary group, boost pump integrated	Charge pump displacement (cc/rev)	145	175	215	280	Code
		32	●				FA
		39		●			FB
		47			●		FC
		60				●	FD

Type introduction

Through drive

		145	175	215	280	Code	
⑫	Through drive	●	●	●	●	Blank	
	Without through drive					Blank	
	Flange	Splined shaft					
	SAE A J744-82-2	ANSI B92.1b 5/8 in 9T 16/32 DP	●	●	●	●	A1
	SAE B J744-101-2	ANSI B92.1b 7/8 in 13T 16/32DP	●	●	●	●	B1
		ANSI B92.1b 1 in 15T 16/32 DP	●	●	●	●	B3
	SAE C J744-127-2/4	ANSI B92.1b 1 1/4 in 14T 12/24 DP	●	●	●	●	CC
		ANSI B92.1b 1 3/4 in 13T 8/16 DP	●	●	●	●	CD
		ANSI B92.1b 1 1/4 in 17T 12/24 DP			●		CG
	SAE D J744-152-2/4	ANSI B92.1b 1 3/4 in 13T 8/16 DP	●	●	●	●	D1
		DIN 5480 N40×2×18×9g			●	●	D4
	SAE E J744-165-4	ANSI B92.1b 1 3/4 in 13T 8/16 DP	●	●	●	●	E1
ANSI B92.1b 2 in 15T 8/16DP				●	●	E3	

Relief valve

		145	175	215	280	Code
⑬	Relief valve	Setting range Δp				
	Direct-acting high-pressure relief valve, fixed setting	●	●	●	●	8

Filtration boost circuit/external boost pressure supply

		145	175	215	280	Code
⑭	Filtration boost circuit/external boost pressure supply	●	●	●	●	Blank
	External boost pressure supply (version without integrated boost pump)	●	●	●	●	S
	Filtration in the boost pump suction line	●	●	●	●	D
	Filtration in the boost pump pressure line (ports with external filter circuit)	●	●	●	●	F
	Filtration in the boost pump pressure line (with filter)			○	○	B
	Filtration in the boost pump pressure line (with filter, cold start valve, contamination indicator)			○	○	B

Flushing valve

		145	175	215	280	Code
⑮	Flush valve(Opening pressure 16bar, differential pressure $\Delta P=25bar$.)	●	●	●	●	Blank
	Without flush valve	●	●	●	●	Blank
	Flushing flow 20 (L/min)				●	4

Standard / special version

		145	175	215	280	Code
⑮	Standard / Special version	●	●	●	●	Blank
	Standard version	●	●	●	●	Blank
	Special version					S

Remark: ● = Available; ○ = On request

Hydraulic fluid

Viscosity and temperature of the hydraulic fluid

	Viscosity(mm ² /s)	Oil seal	Temperature	Note
Cold start	$v_{max} \leq 1600$	NBR	$\theta_{st} \geq -40^{\circ}C$	$t \leq 3$ minutes, no load ($p \leq 50$ bar), $n \leq 1000$ rpm, Maximum permissible temperature difference between the rotating parts of the system and the hydraulic fluid 25° C.
		FKM	$\theta_{st} \geq -25^{\circ}C$	
Warm-up phase	$v = 1600 \cdots 400$			$t \leq 15$ minutes, $p \leq 0.7 \times p_{nom}$, $n \leq 0.5 \times n_{nom}$
Continuous operation	$v = 400 \cdots 10$	NBR	$\theta \leq +85^{\circ}C$	Measured at oil port T
		FKM	$\theta \leq +110^{\circ}C$	
	$v_{opt} = 36 \cdots 16$			Optimum operating viscosity and efficiency range
Short-term operation	$v_{min} = 10 \cdots 7$	NBR	$\theta \leq +85^{\circ}C$	$t \leq 3$ minutes, $p \leq 0.3 \times p_{nom}$, Measured at oil port T
		FKM	$\theta \leq +110^{\circ}C$	

Selection chart

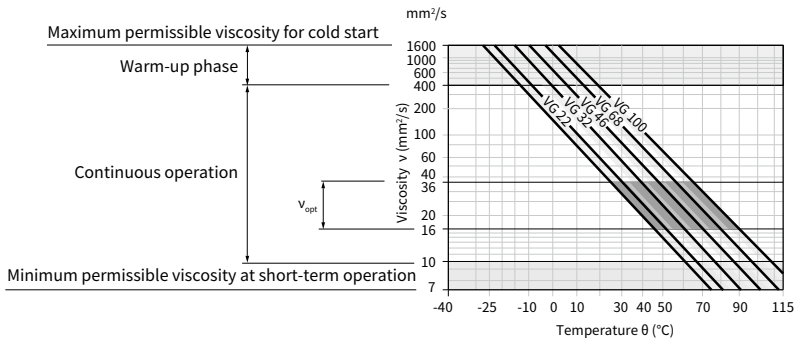

Detailed information on the selection of hydraulic fluids

To select the hydraulic fluid correctly, it is necessary to know the operating temperature in relation to the ambient temperature: in closed circuits the oil circuit temperature.

When selecting a hydraulic fluid, the operating viscosity should be in the optimum range for the operating temperature range (v_{opt} , see shaded area of the selection chart). We recommend selecting a higher viscosity grade in all cases.

Example: When the operating temperature in the circuit is 60° C, in the optimum operating viscosity range (shaded area of the v_{opt}), corresponding to viscosity grades VG46 or VG68; VG68 should be selected.

Caution

The case drain temperature (influenced by pressure and speed) may be higher than the oil line temperature or tank temperature.

However, the temperature of any part of the component must not exceed 100° C.

Hydraulic fluid

Filtration of hydraulic fluid

Finer filtration improves the cleanliness of the hydraulic fluid, thereby extending the life of rotating parts. A cleanliness of at least 20/18/15 (ISO 4406) should be maintained. When the viscosity of the hydraulic fluid is less than $10\text{mm}^2/\text{s}$ (e.g. due to high temperatures during short-term operation, a cleanliness level of at least 19/17/14 (ISO 4406) is required.

Oil seals

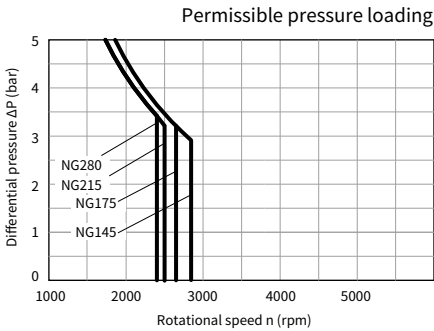

▲ Note

- When using mineral oil based hydraulic fluid, refer to the left diagram for the range of pressures used for oil seals, please contact us if other hydraulic fluids are used.
- The service life of the oil seal is affected by the rotational speed and the pressure difference between the inside and outside of the seal, in addition to the hydraulic oil and temperature.
- The pressure difference between the inside and outside of the seal must be greater than or equal to zero.

E - Electrical displacement control

• Electrical displacement control principle

The output flow of the pump is infinitely variable between 0 and 100%, proportional to the electrical current supplied to solenoid a or b.

The electrical energy is converted into a force acting on the control spool.

This control spool then directs control oil into and out of the stroking cylinder to adjust pump displacement as required.

A feedback lever connected to the stroking piston maintains the pump flow for any given current within the control range.

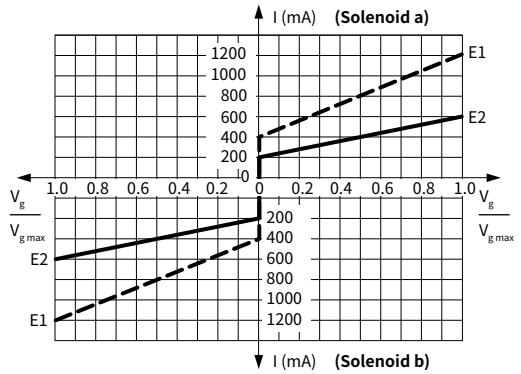

Standard:

Proportional solenoid without manual emergency operation.

Supply as required:

Proportional solenoid with manual emergency operation and spring return.

Technical data, solenoid

Control		E1	E2
Voltage		12 V (±20%)	24 V (±20%)
Control current	Start of control at $V_g=0$	400 mA	200 mA
	End of control at $V_{g,max}$	1200 mA	600 mA
Current limit		1540 mA	840 mA
Nominal resistance (at 68 °F (20°C))		5.5 Ω	21.7 Ω
Dither frequency		100Hz / 120Hz (120Hz only for the V40G175 closed pumps)	
Duty cycle		100%	
Type of protection		See connector version	

Note:

The spring-return device in the control module is not a safety device

The control module may be stuck in an uncertain position by internal impurities (hydraulic oil impurities, system component wear or sediment). As a result, the controller can no longer respond correctly to the instruction from the operator.

Check whether additional safety measures are required on your machine to move the drive actuator to a controlled safe position (emergency stop). When necessary, please ensure that these operations are implemented correctly.

H2 - Proportional control, hydraulic, pilot-pressure related

· Hydraulic proportional control principle

The output flow of the pump is infinitely variable between 0 and 100%, proportional to the difference in pilot pressure applied to the two pilot pressure ports (Y1 and Y2). The pilot signal, coming from an external source, is a pressure signal. Flow is negligible, as the pilot signal acts only on the control spool of the control valve.

This control spool then directs control oil into and out of the stroking cylinder to adjust pump displacement as required.

A feedback lever connected to the stroking piston maintains the pump flow for any given pilot signal within the control range.

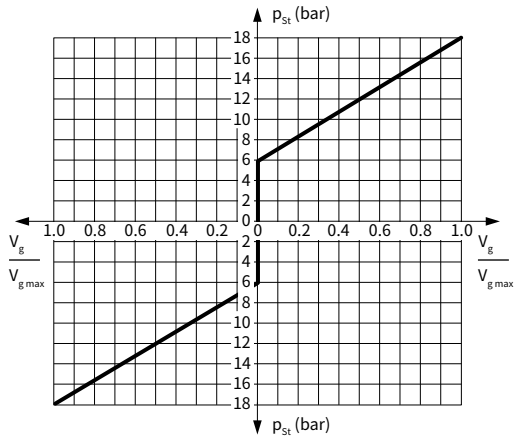

Displacement at $V_g = pSt$

Displacement at $V_g \max = pSt = 18\text{bar}$

Pilot signal $pSt = 6$ to 18 bar (at port Y1, Y2)

Initial control value at 6 bar pressure

Control termination value when the pressure is 18 bar

(The maximum displacement $V_g \max$)

Note:

In the neutral position, the HD control module must be unloaded to reservoir via the external pilot control device.

Note:

The spring-return device in the control module is not a safety device

The control module may be stuck in an uncertain position by internal impurities (hydraulic oil impurities, system component wear or sediment). As a result, the controller can no longer respond correctly to the instruction from the operator.

Check whether additional safety measures are required on your machine to move the drive actuator to a controlled safe position (emergency stop). When necessary, please ensure that these operations are implemented correctly.

V40G 145 Control principle

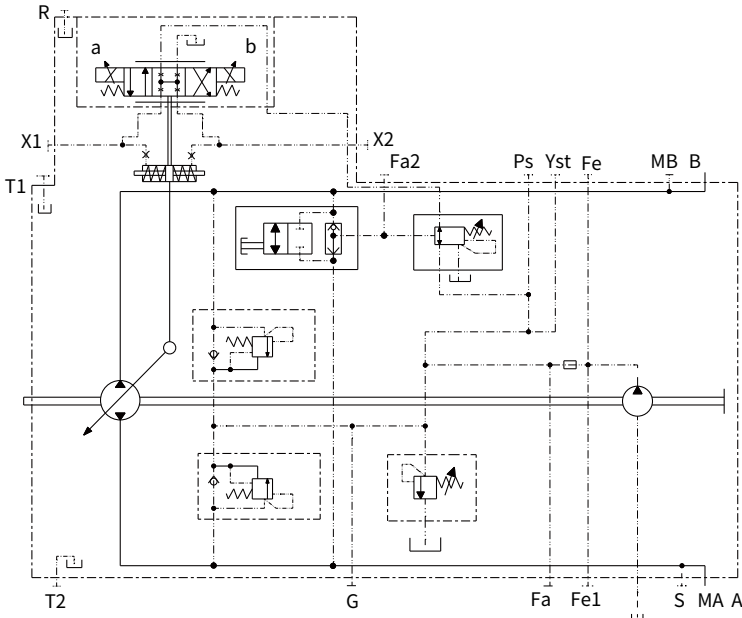

Direction of rotation	Clockwise		Counter-clockwise	
	a	b	a	b
Actuation of proportional solenoid	X1	X2	X1	X2
Flow direction	B to A	A to B	A to B	B to A
Working pressure	MA	MB	MB	MA

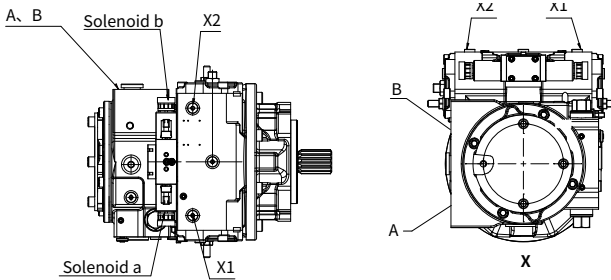

Installation size

V40G 145 Installation size

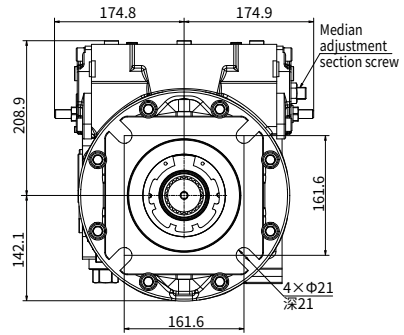
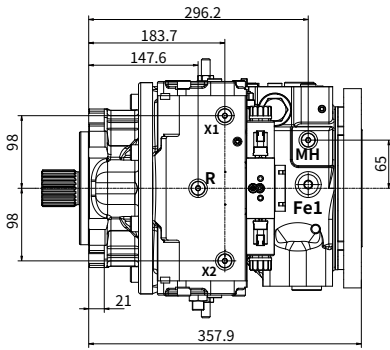

X View

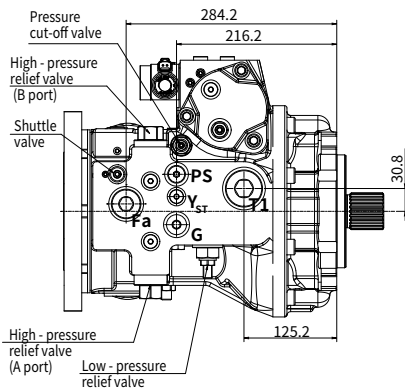
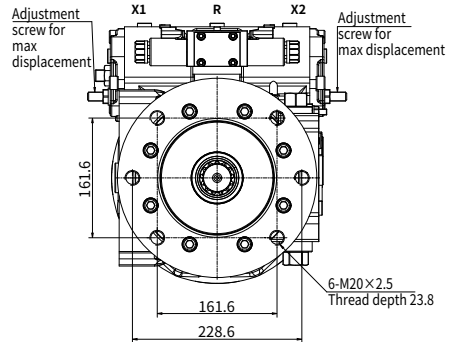
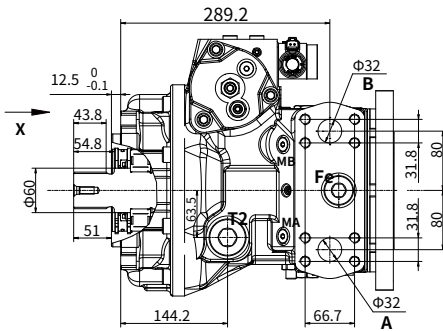

Y View

Installation size

•V40G 145 Port details

Port	Port Name	Standard	Oil Port Specification (thread depth)	Maximum pressure (bar)
A, B	Working port	SAE J518	1 1/4in	500
	Fastening thread A/B	DIN 13	M14×2 (depth 19)	-
S	Suction port	ISO 9974-1	M48×2 (depth 24)	5
T1, T2	Drain port	ISO 9974-1	M42×2 (depth 20)	3
R	Air bleed port	ISO 9974-1	M14×1.5 (depth 14.1)	3
X1, X2	Control pressure port	ISO 9974-1	M14×1.5 (depth 20)	40
G	Boost pressure port	ISO 9974-1	M22×1.5 (depth 19)	40
P _s	Pilot pressure port inlet	ISO 9974-1	M18×1.5 (depth 17)	40
Y _{ST}	Pilot pressure port outlet	ISO 9974-1	M14×1.5 (depth 17.5)	40
MA, MB	Measuring port pressure A, B	ISO 9974-1	M14×1.5 (depth 15.5)	500
MH	Measuring port, high pressure	ISO 9974-1	M14×1.5 (depth 15)	500
Fe	Boost pressure port (Can be connected to an external filter)	ISO 9974-1	M33×2 (depth 21)	40
Fa	Boost pressure port (Can be connected to an external filter)	ISO 9974-1	M33×2 (depth 17.2)	40
Fe1	Boost pressure port	ISO 9974-1	M22×1.5 (depth 18.5)	40

Installation size

·V40G145 Shaft extension type

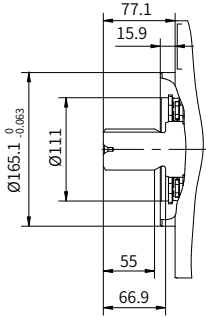

"E1" type spline shaft

ANSI B92.1b

1 3/4 in 13T-8/16 DP

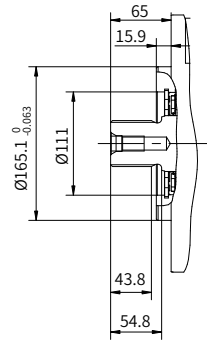

"E5" type spline shaft

DIN 5480

W50×2×24×9g

Installation size

·V40G145 Through shaft drive

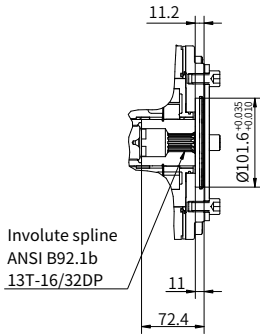

“B1” type through drive

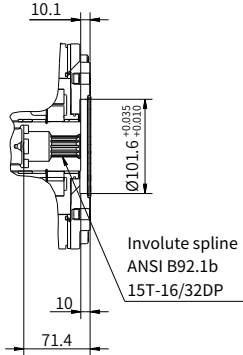

“B3” type through drive

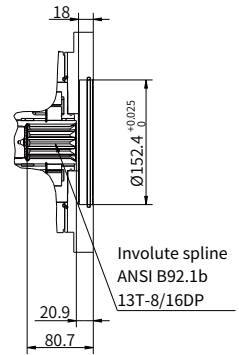

“D1” type through drive

02

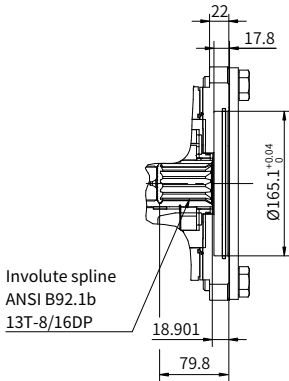

“E1” type through drive

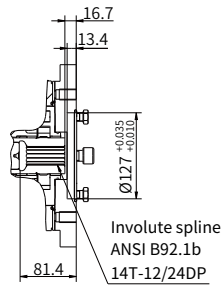

“CC” type through drive

V40G 175 Control principle

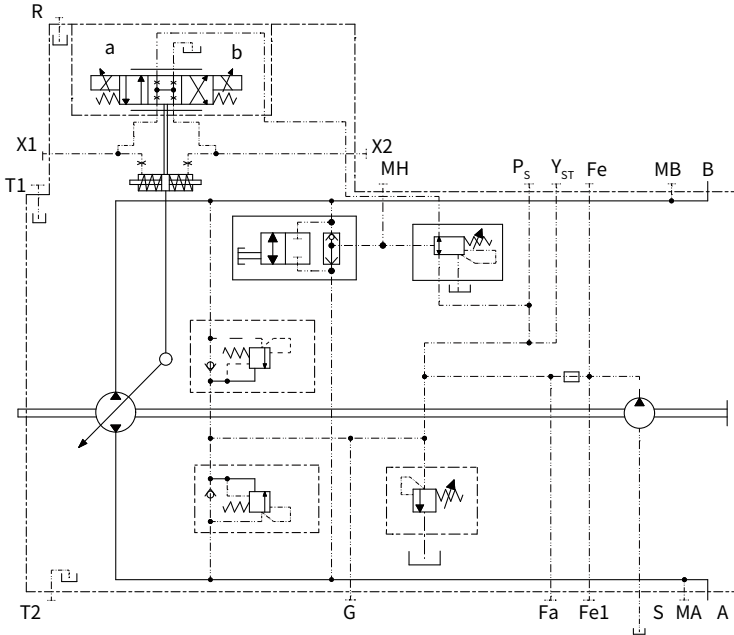

02

Direction of rotation	Clockwise		Counter-clockwise	
	a	b	a	b
Actuation of proportional solenoid	X1	X2	X1	X2
Control pressure	B to A	A to B	A to B	B to A
Flow direction	MA	MB	MB	MA
Working pressure				

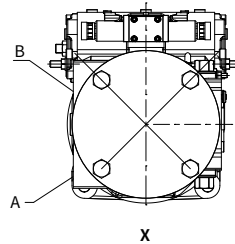
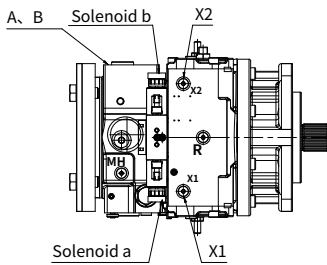

Installation size

V40G 175 Installation size

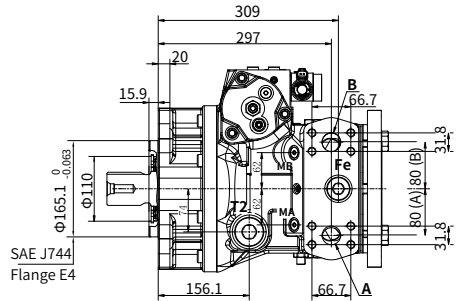
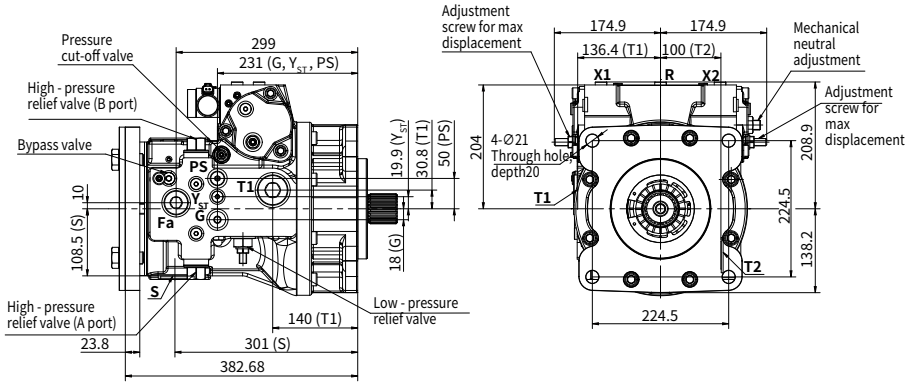
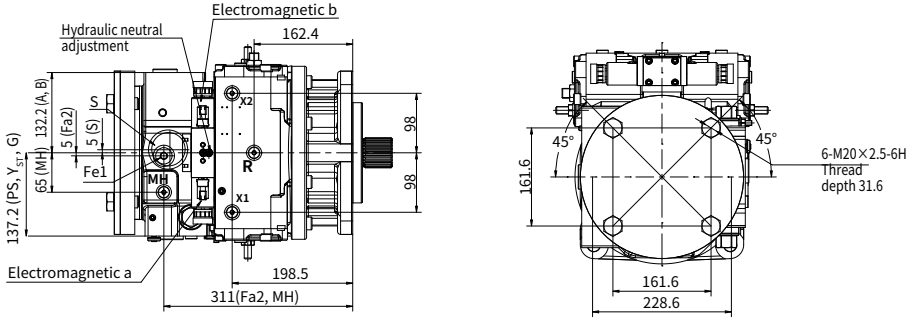

02

Installation size

·V40G 175 Port details

Port	Port Name	Standard	Oil Port Specification (thread depth)	Maximum pressure (bar)
A, B	Working port	SAE J518	1 1/4in	500
	Fastening thread A/B	DIN 13	M14×2 (depth 19)	-
S	Suction port	ISO 9974-1	M48×2 (depth 22)	5
T1, T2	Drain port	ISO 9974-1	M42×2 (depth 19.5)	3
R	Air bleed port	ISO 9974-1	M14×1.5 (depth 11.5)	3
X1, X2	Control pressure port	ISO 9974-1	M14×1.5 (depth 11.5)	40
G	Boost pressure port	ISO 9974-1	M22×1.5 (depth 15.5)	40
P _s	Pilot pressure port inlet	ISO 9974-1	M18×1.5 (depth 14.5)	40
Y _{ST}	Pilot pressure port outlet	ISO 9974-1	M14×1.5 (depth 11.5)	40
MA, MB	Measuring port pressure A, B	ISO 9974-1	M14×1.5 (depth 11.5)	500
MH	Measuring port, high pressure	ISO 9974-1	M14×1.5 (depth 11.5)	500
Fa	Boost pressure port (Can be connected to an external filter)	ISO 9974-1	M33×2 (depth 17.2)	40
Fe	Boost pressure port (Can be connected to an external filter)	ISO 9974-1	M33×2 (depth 21)	40
Fe1	Boost pressure port	ISO 9974-1	M22×1.5 (depth 18.5)	40

Installation size

·V40G175 Shaft extension type

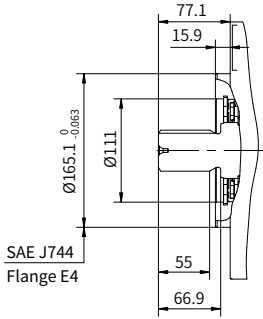

"E1" type spline shaft

ANSI B92.1b
1 3/4 in 13T-8/16 DP

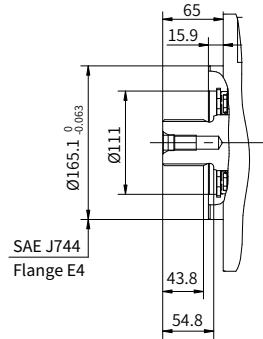

"E5" type spline shaft

DIN 5480
W50×2×24×9g

Installation size

·V40G175 Through shaft drive

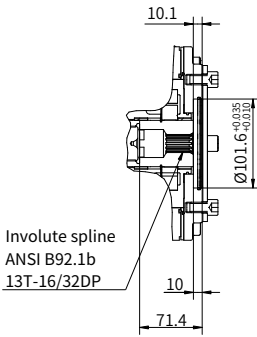

**“B1” type
through drive**

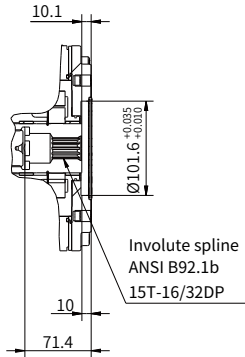

**“B3” type
through drive**

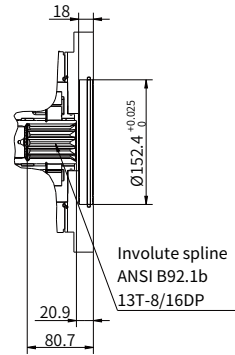

**“D1” type
through drive**

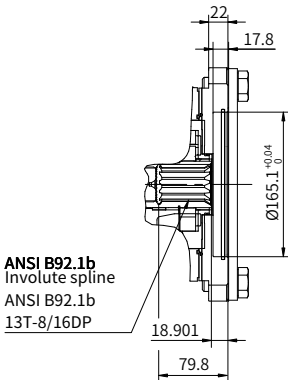

**“E1” type
through drive**

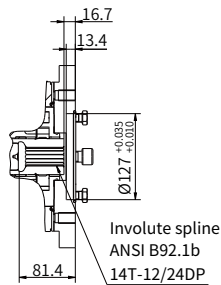

**“CC” type
through drive**

V40G 215 Control principle

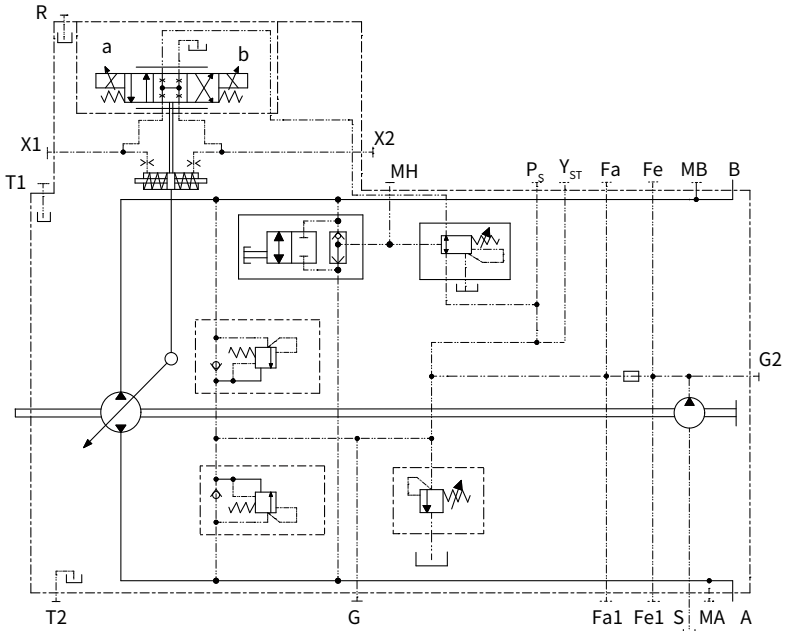

Direction of rotation	Clockwise		Counter-clockwise	
Actuation of proportional solenoid	a	b	a	b
Control pressure	X1	X2	X1	X2
Flow direction	B to A	A to B	A to B	B to A
Working pressure	MA	MB	MB	MA

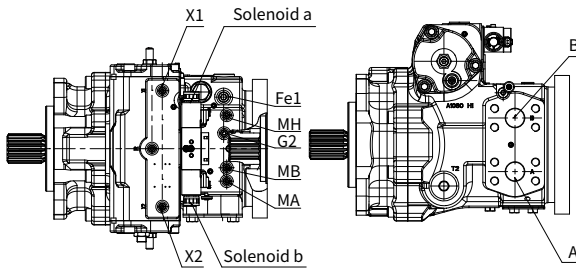

·V40G 215 Port details

Port	Port Name	Standard	Oil Port Specification (thread depth)	Maximum pressure (bar)
A, B	Working port	SAE J518	1 1/2"	500
	Fastening thread A/B	DIN 13	M16×2 (depth 21)	-
S	Suction port	SAE J518	1 1/2"	5
	Fastening thread	DIN 13	M12×1.75 (depth 20)	-
T1, T2	Drain port	ISO 6149	M42×2 (depth 19.5)	3
R	Air bleed port	ISO 6149	M14×1.5 (depth 11.5)	3
X1, X2	Control pressure port	ISO 6149	M14×1.5 (depth 11.5)	40
G	Boost pressure port	ISO 6149	M22×1.5 (depth 15.5)	40
G2	Boost pressure port	ISO 6149	M14×1.5 (depth 12)	40
P _s	Pilot pressure port inlet	ISO 6149	M18×1.5 (depth 14.5)	40
Y _{ST}	Pilot pressure port outlet	ISO 6149	M14×1.5 (depth 11.5)	40
MA, MB	Measuring port pressure A, B	ISO 6149	M14×1.5 (depth 11.5)	500
MH	Measuring port, high pressure	ISO 6149	M14×1.5 (depth 11.5)	500
Fa	Boost pressure port(Can be connected to an external filter)	ISO 6149	M33×2 (depth 19)	40
Fa1	Boost pressure port (DA valve reserved port)	ISO 6149	M42×2 (depth 18)	40
Fe	Boost pressure port(Can be connected to an external filter)	ISO 6149	M33×2 (depth 19)	40
Fe1	Boost pressure port	ISO 6149	M22×1.5 (depth 19.5)	40

Installation size

·V40G215 Shaft extension type

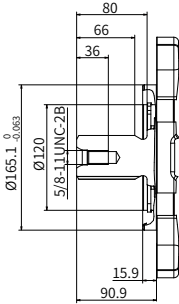

“E3” type spline shaft

ANSI B92.1b
2 in 15T-8/16 DP

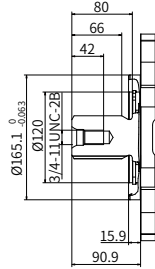

“E4” type spline shaft

ANSI B92.1b
2 1/4 in 17T-8/16 DP

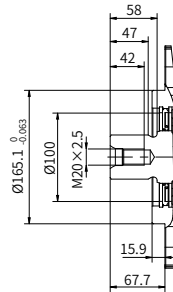

“E6” type spline shaft

DIN 5480
W55x2x26x9g

Installation size

·V40G215 Through shaft drive

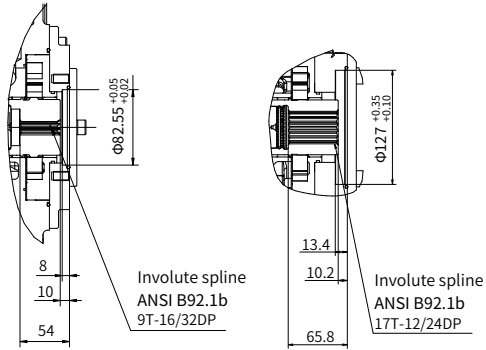

**"A1" type
through drive**

**"CG" type
through drive**



02

V40G 280 Control principle

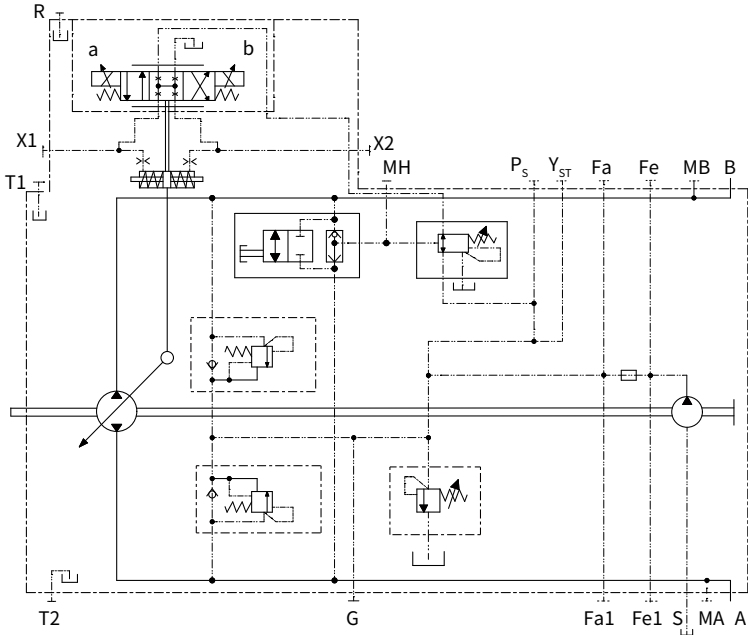

Direction of rotation	Clockwise		Counter-clockwise	
Actuation of proportional solenoid	a	b	a	b
Control pressure	X1	X2	X1	X2
Flow direction	B to A	A to B	A to B	B to A
Working pressure	MA	MB	MB	MA

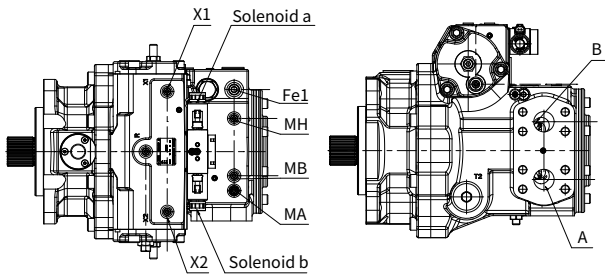

Installation size

V40G 280 Installation size

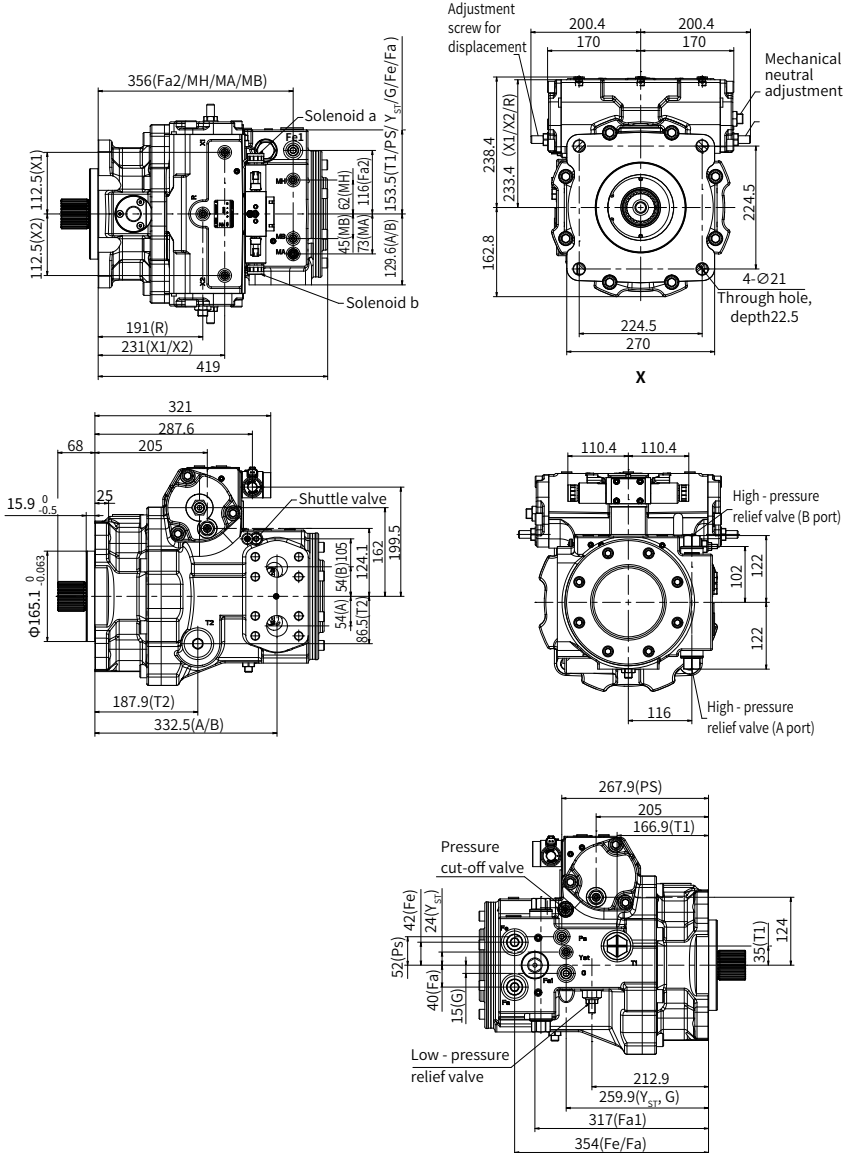

02

·V40G 280 Port details

Port	Port Name	Standard	Oil Port Specification (thread depth)	Maximum pressure (bar)
A, B	Working port	SAE J518	1 1/2"	500
	Fastening thread A/B	DIN 13	M16×2 (depth 21)	-
S	Suction port	SAE J518	1 1/2"	5
	Fastening thread	DIN 13	M12×1.75 (depth 20)	-
T1, T2	Drain port	ISO 6149	M42×2 (depth 19.5)	3
R	Air bleed port	ISO 6149	M14×1.5 (depth 11.5)	3
X1, X2	Control pressure port	ISO 6149	M14×1.5 (depth 11.5)	40
G	Boost pressure port	ISO 6149	M22×1.5 (depth 15.5)	40
P _s	Pilot pressure port inlet	ISO 6149	M18×1.5 (depth 14.5)	40
Y _{ST}	Pilot pressure port outlet	ISO 6149	M14×1.5 (depth 11.5)	40
MA, MB	Measuring port pressure A, B	ISO 6149	M14×1.5 (depth 11.5)	500
MH	Measuring port, high pressure	ISO 6149	M14×1.5 (depth 11.5)	500
Fa	Boost pressure port (Can be connected to an external filter)	ISO 6149	M33×2 (depth 19)	40
Fa1	Boost pressure port (DA valve reserved port)	ISO 6149	M42×2 (depth 18)	40
Fe	Boost pressure port (Can be connected to an external filter)	ISO 6149	M33×2 (depth 19)	40
Fe1	Boost pressure port	ISO 6149	M22×1.5 (depth 15.5)	40

Installation size

·V40G280 Shaft extension type

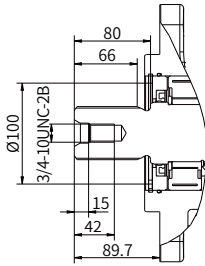

“E4” type spline shaft

ANSI B92.1b
2 1/4 in 17T-8/16DP

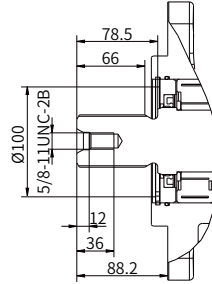

“E3” type spline shaft

ANSI B92.1b
2 in 15T-8/16DP

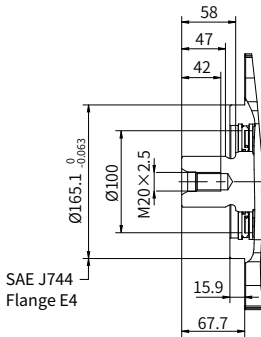

“E6” type spline shaft

DIN 5480
W55×2×26×9g

Installation size

·V40G280 Through shaft drive

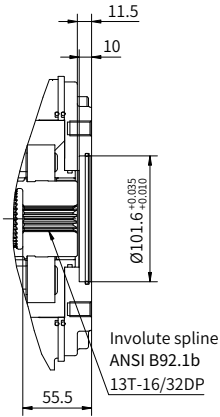

"B1" type
through drive

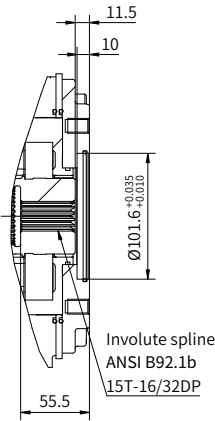

"B3" type
through drive

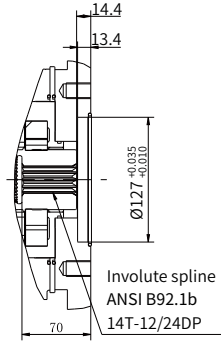

"C6" type
through drive

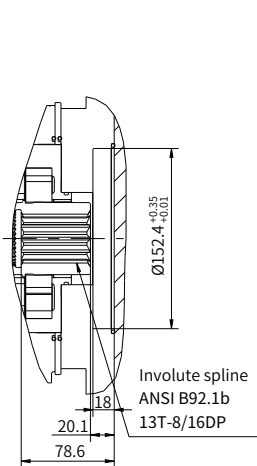

"D1" type
through drive

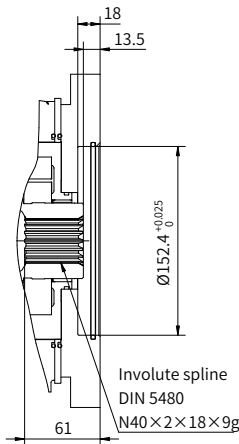

"D4" type
through drive

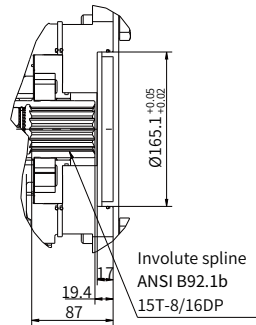

"E3" type
through drive



© Hengli Hydraulics retains the copyright, trade mark rights and other intellectual property rights in all contents of this brochure. No part of this brochure may be reproduced, edited, duplicated or electronically transmitted in any way without authorisation. As products are constantly being optimised and innovated, we do not warrant that all information is completely accurate, complete or up-to-date at any point in time.