

2.10



HDL series

Orbital hydraulic motor

HDL series orbital hydraulic motor is a rotor distribution hydraulic motor with independent intellectual property rights of Hengli, which uses a special patented end face compensation structure, which can achieve high volumetric efficiency, high starting efficiency and good load retention under high pressure conditions.

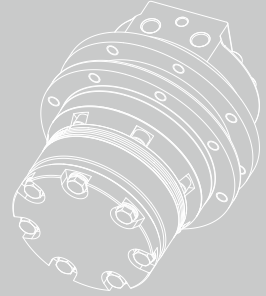

Contents

Overview	02
Advantages	02
Applications	02
Specification	03
Ordering information	04
Installation size	05
Shaft end dimensions	05-06
Length and weight	06
Hydraulic diagram	06
Rotation direction	07



Overview

HDL series orbital hydraulic motor is a rotor distribution hydraulic motor with independent intellectual property rights of Hengli, which uses a special patented end face compensation structure, which can achieve high volumetric efficiency, high starting efficiency and good load retention under high pressure conditions, and is suitable for the crawler travelling drive of mini excavators.

Advantages

- Adoption of wheelside output for compact installation enables high throughput.
- The unique balance plate design ensures stable operation at low speeds and high pressures.
- The advanced flow distribution system design greatly improves efficiency and makes the motor more compact.
- A variety of flange connection sizes are provided, facilitating installation.

02

Applications

- Mini excavator
- Mini spider aerial worker platform
- Mini skid steer loader(crawler)
- Mini crawler dump truck
- Crawler wood chipper
- Multi-functional remote-controlled robots

Specification

Type		HDL-300	HDL-350	HDL-400
Displacement	cc	291	328	400
Theoretical max. output torque	N · m	959	1081	1018
Max. differential pressure	bar	207	207	207
Max. speed	rpm	100	100	100
Mechanical braking torque	N · m	—	—	—
Drain port	—	Required	Required	Required
Applicable tonnage	Ton	0.8~1.0	1.0~1.3	1.3~1.5
Weight(kg)		20.418	20.658	21.133

T-0152

- It is not recommended that the motor be at max. torque and max. speed at the same time.
- The filtration standard of ISO 4406 cleaning standard 20/18/13 is recommended.
- High quality anti-wear hydraulic fluids are recommended.
- When the temperature is 50° C, the minimum viscosity of the oil is recommended to be 20mm²/s.
- The recommended maximum operating temperature is 82° C .
- To assure best motor life, run motor for approx. 1 hour at 30% of rated load before operating at full load, and the motor should be made sure that the inside of the motor is filled with oil before it is run.

Ordering information

HDL	300	H06	S1	A	N	A
①	②	③	④	⑤	⑥	⑦

Orbital Hydraulic Series

①	Orbital Hydraulic Motor	HDL
---	-------------------------	-----

Type

②	Type	300	350	400
---	------	-----	-----	-----

Mount, Port

③	Installation of 8×M10 distribution circle Ø157, port G3/8, drain port G1/8	H06
	Installation of 8×M10 distribution circle Ø155, port G3/8, drain port G1/8	H07
	Installation of 8×M10 distribution circle Ø155, port G3/8, drain port G1/4, O-ring seal	H10

Output Shaft

④	Shell turn, pilot Ø140×6, 8×M10 distribution circle Ø157	S1
	Shell turn, pilot Ø140×6, 9×M10 distribution circle Ø155	S2

Rotation Direction

⑤	CW	A
	CCW	R

Paint Option

⑥	No Paint	N
	Black	B
	Hengli blue	C

Special Features

⑦	Standard	A
	Free running	F

T - 0154

Note: When using the order information, the user can select the motor series, displacement, installation flange, port, shaft and other information. If the selected specification is not in the table or has special requirements, please contact us.

Installation size

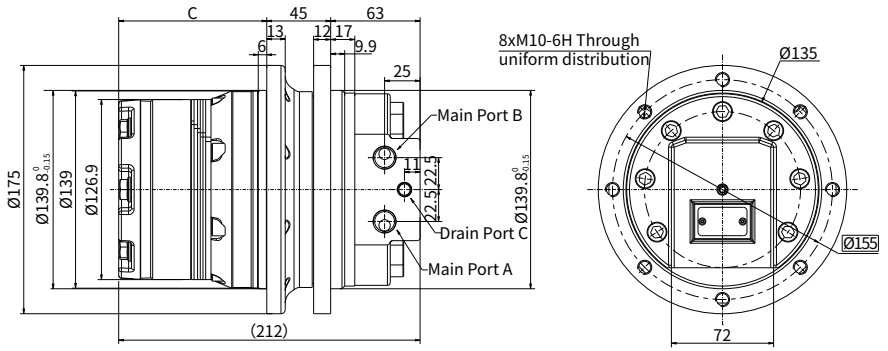

P-0184

Code	Distribution circle	Port A/B	Drain port C
H06	Ø157	G3/8	G1/8
H07	Ø155		G1/4
H10			

T - 0237

Shaft end dimension

S1 Shell turn, pilot diameter Ø140×6, 8×M10 distribution circle Ø157

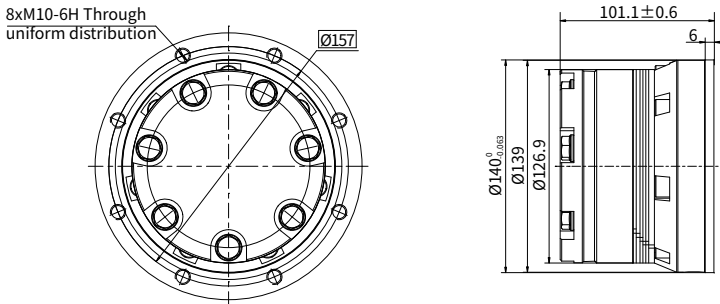

P-0185

Shaft end dimension

S2 Shell turn, pilot diameter $\varnothing 140 \times 6, 9 \times 10$ distribution circle $\varnothing 155$

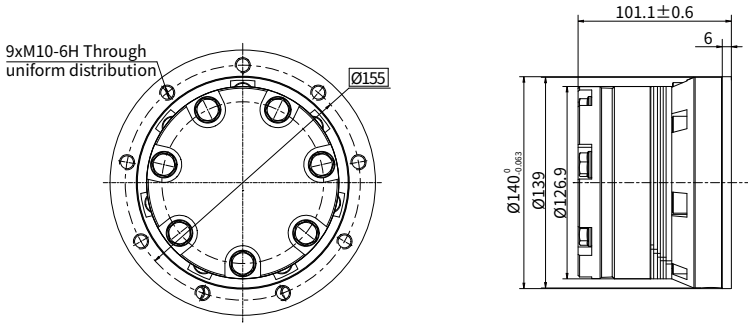

P-0186

Length and weight

Type	C mm	Weight kg
300	101.1	20.418
350	104.3	20.658
400	110.6	21.133

T-0153

Note: Dimensions C are the length from the flange mounting surface to the rear end of the motor, and the tolerance is ± 0.6 .

Hydraulic diagram

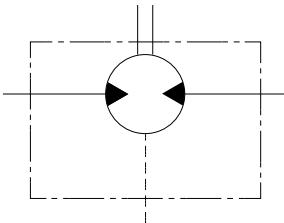

P-0190

Rotation direction: CW

When facing the motor shaft extension direction, port A is high pressure oil, the output shaft rotates CW; Otherwise, it rotates CCW.

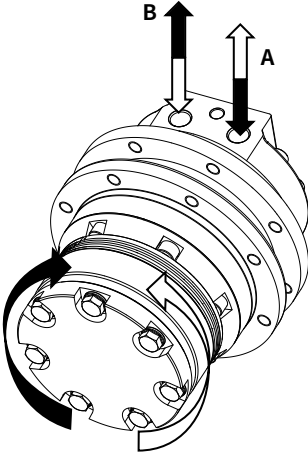

P-0189

